

WIRING A RELAY TO INTERRUPT IMMOBILIZER BYPASS MODULE

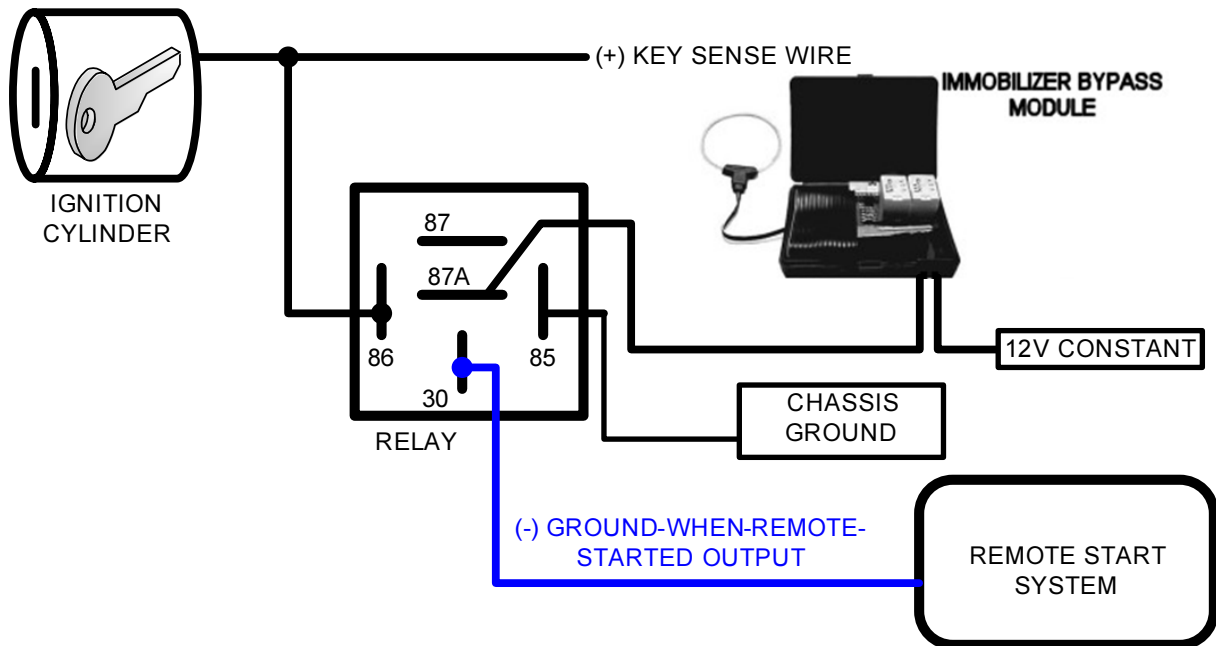

NOTE:

On 2001-Up Mazda Tributes and Ford Escapes, use the BLACK/PINK (+) key sense wire at the steering column to interrupt the Immobilizer bypass unit, so that when the key is inserted to do take over the vehicle does not see two transponders at the same time



PIN	CONNECTION
85	TO CHASSIS GROUND
86	TO (+) KEY-SENSE WIRE
87	NO CONNECTION
87A	TO (-)GROUND-WHEN-REMOTE-STARTED INPUT AT BYPASS MODULE
30	TO (-) GROUND-WHEN-REMOTE-STARTED OUTPUT FROM REMOTE START SYSTEM

Remote starter and security installations should be attempted by experienced security installers only. Information contained is accurate to the best of our knowledge and experience. Information contained is without any representation of warranty. It is the installer's responsibility to test and confirm all circuits with a digital multi-meter. Proper installation remains the responsibility of the installer. CarInstallExperts.com assumes no liability or responsibility resulting from an improper installation, even in reliance with the information contained in this guide.